

077 EPW / EFT



(D) Vor Montage bitte Gebrauchsanleitung lesen!

(I) Prima del montaggio leggere per favore le istruzioni per l'uso!

(F) Prière de lire le mode d'emploi avant de procéder au montage!

(GB) Please read the instructions of use prior to starting installation work!

EPWBO / EFTBO

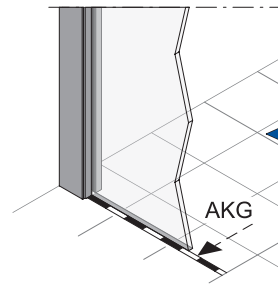

Montage bodengleich

Montage an niveau du sol sans bac de douche

Montaggio a livello del pavimento

Design level with floor without shower basin

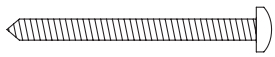

A - 4 x 50 - TX20



B - 3,5 x 32 - TX15



D - 3,5 x 9,5 - TX15

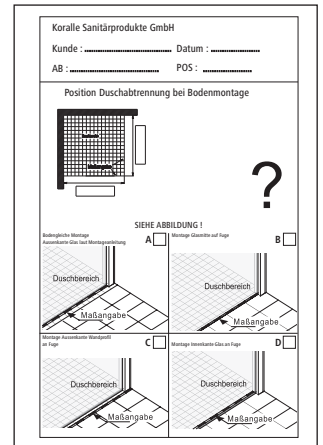
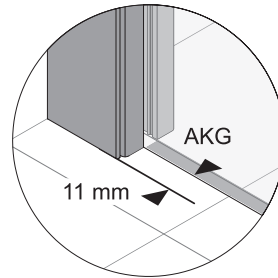

EPW / EFT

1

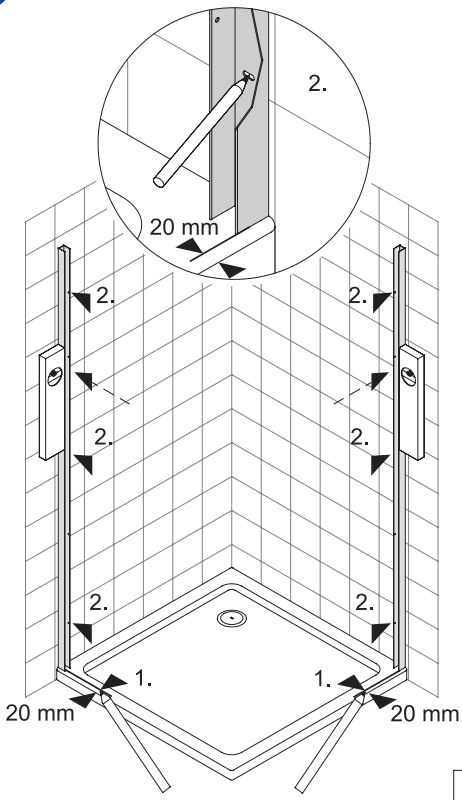

2

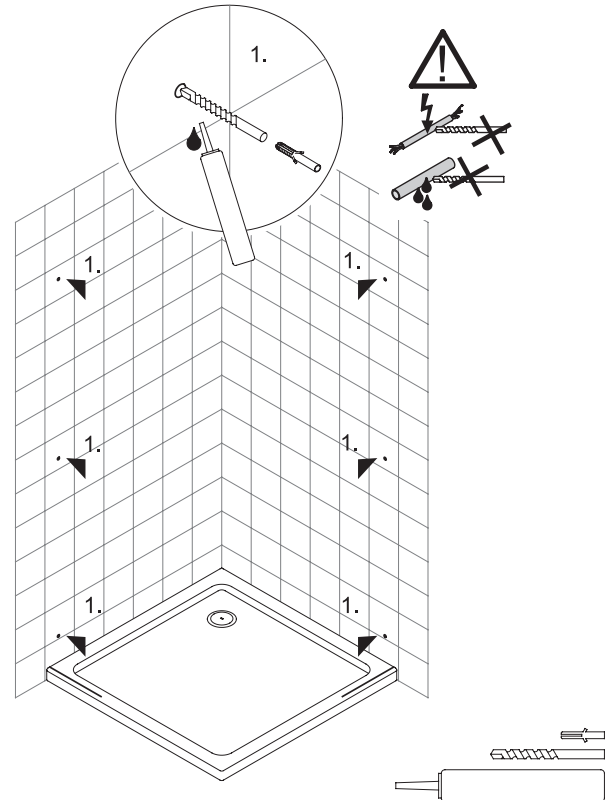

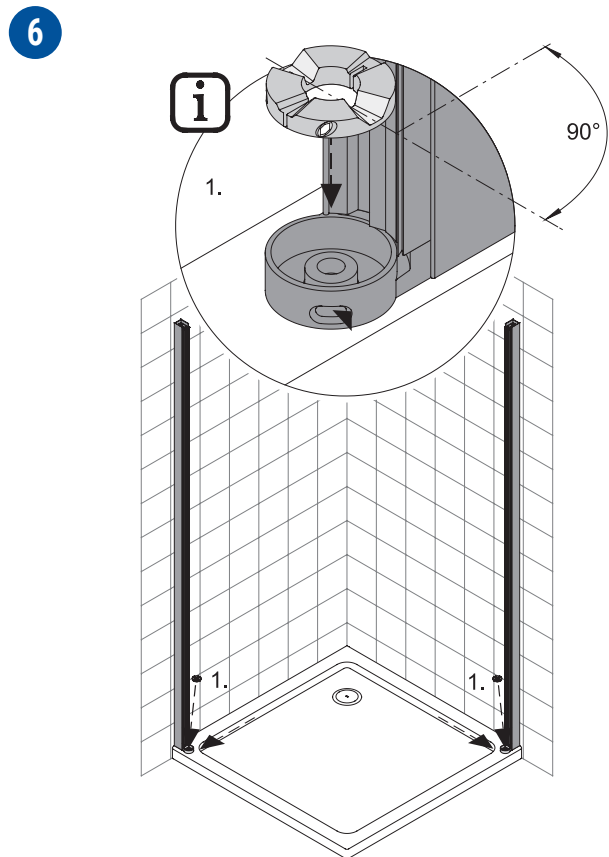
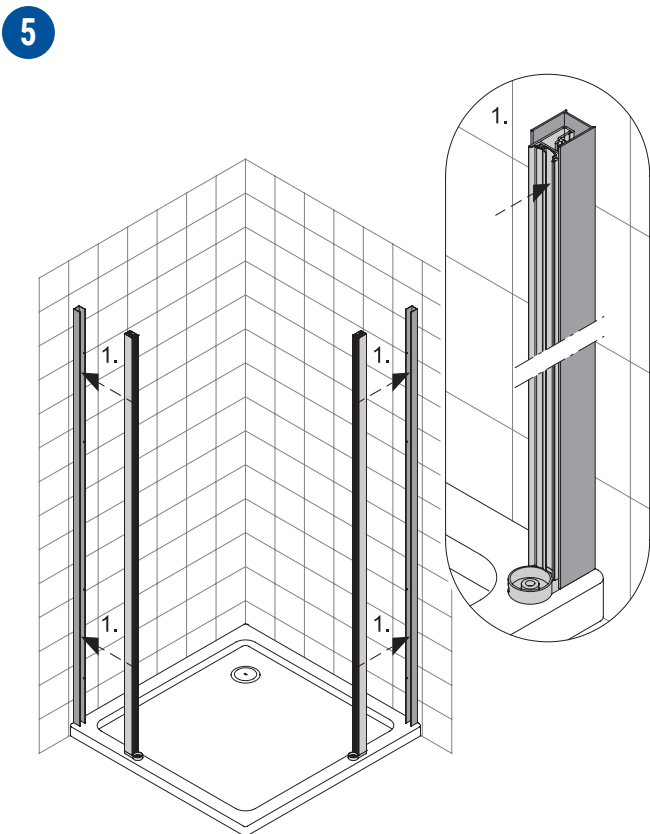
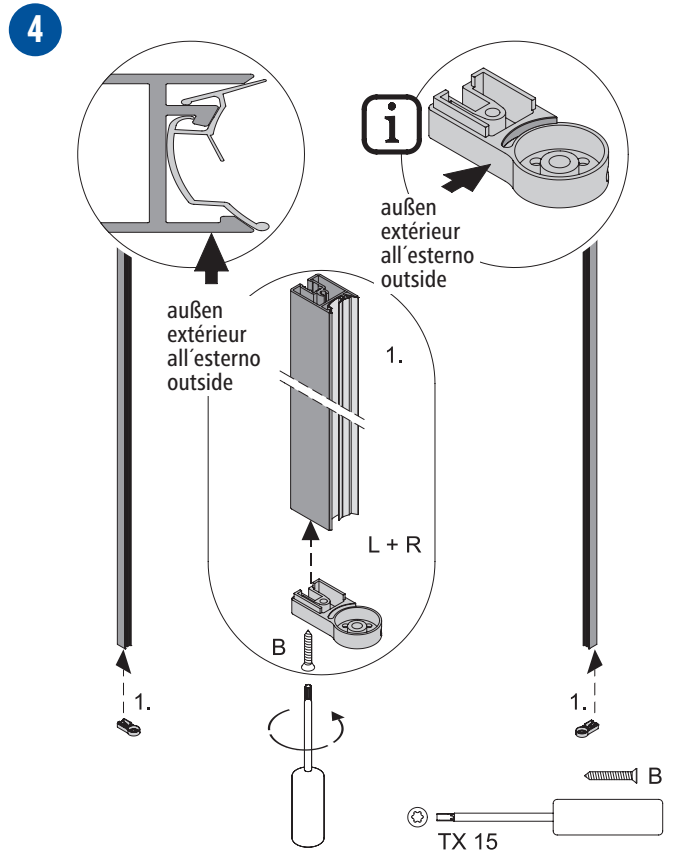
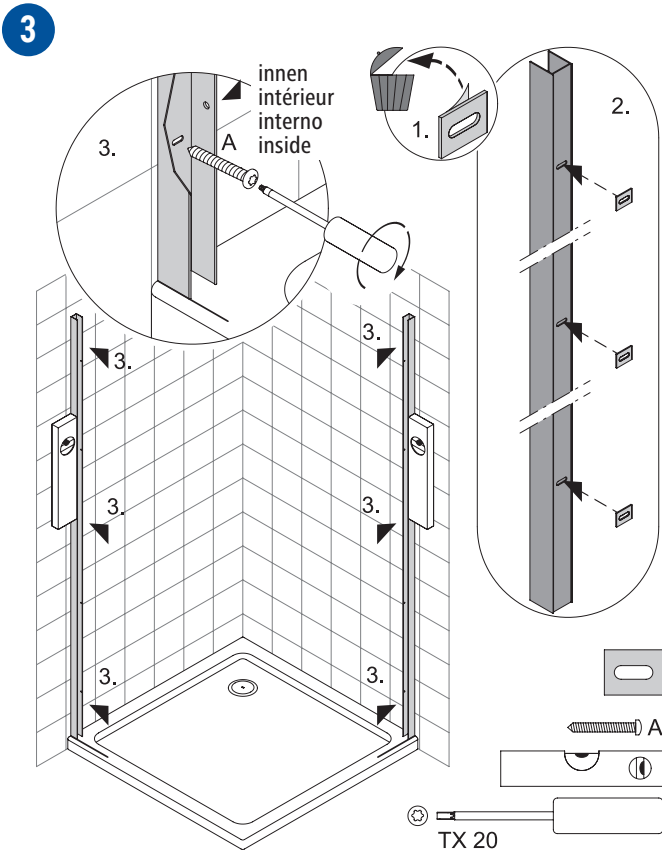

EPW

7

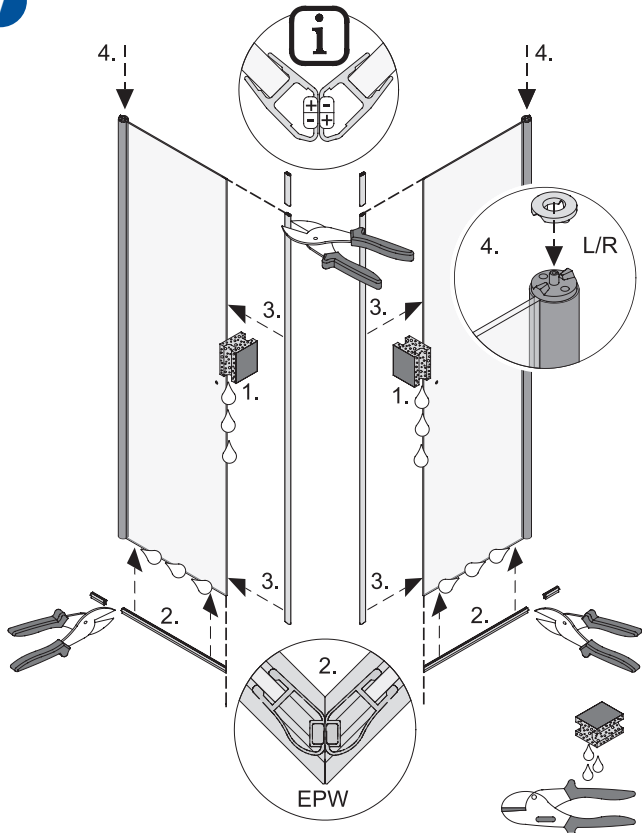

EFT

7b

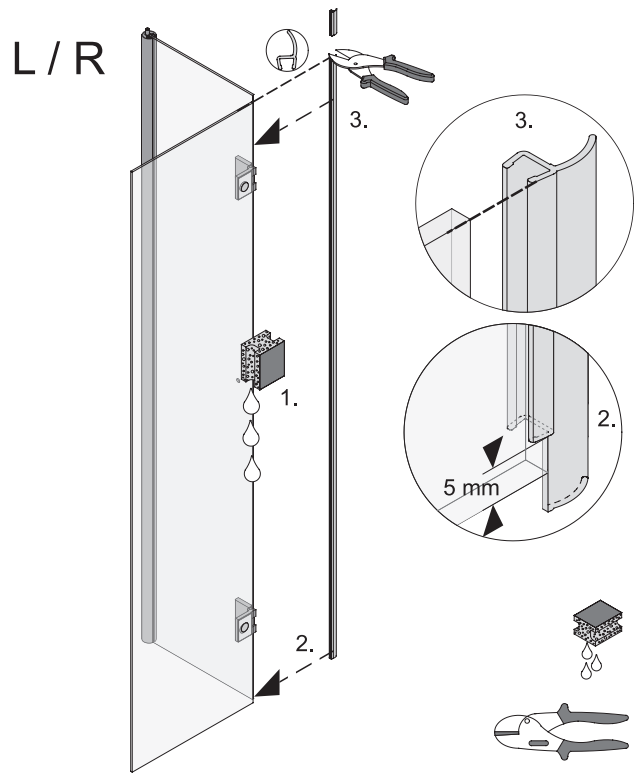

EFT

7c

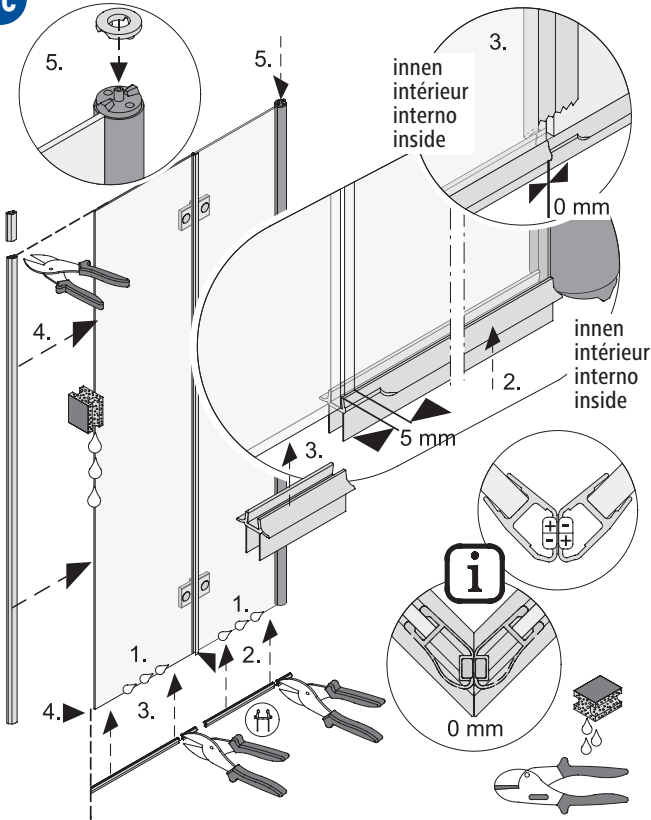

EFT / EPW

8

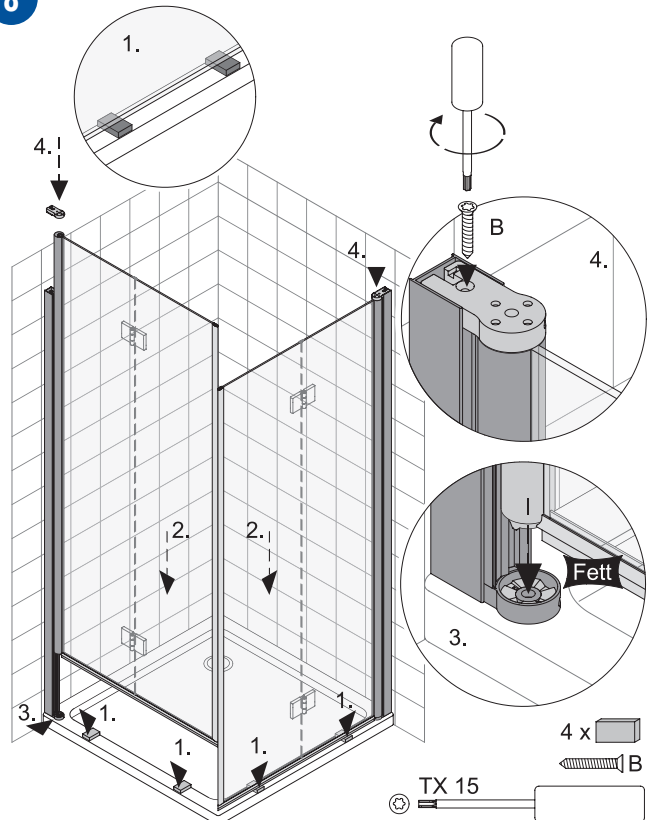

9

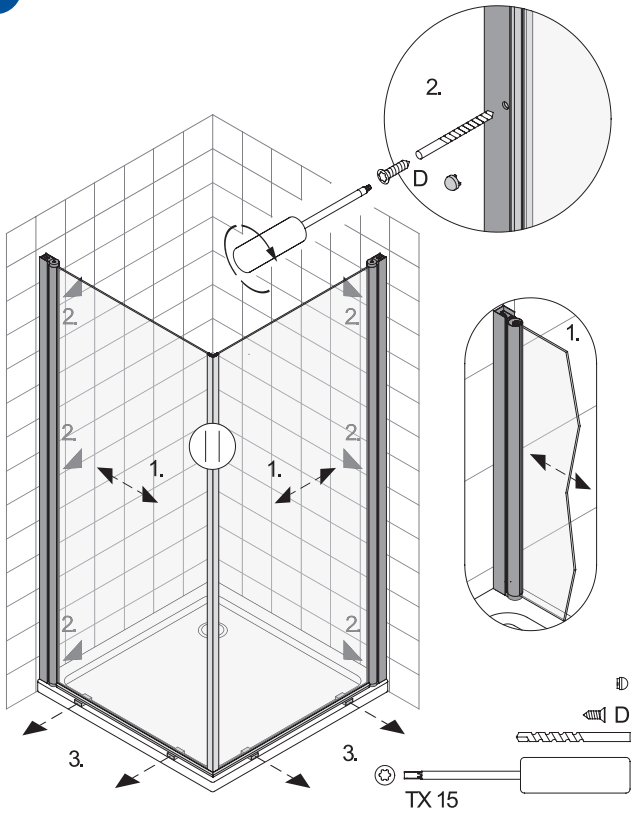

10

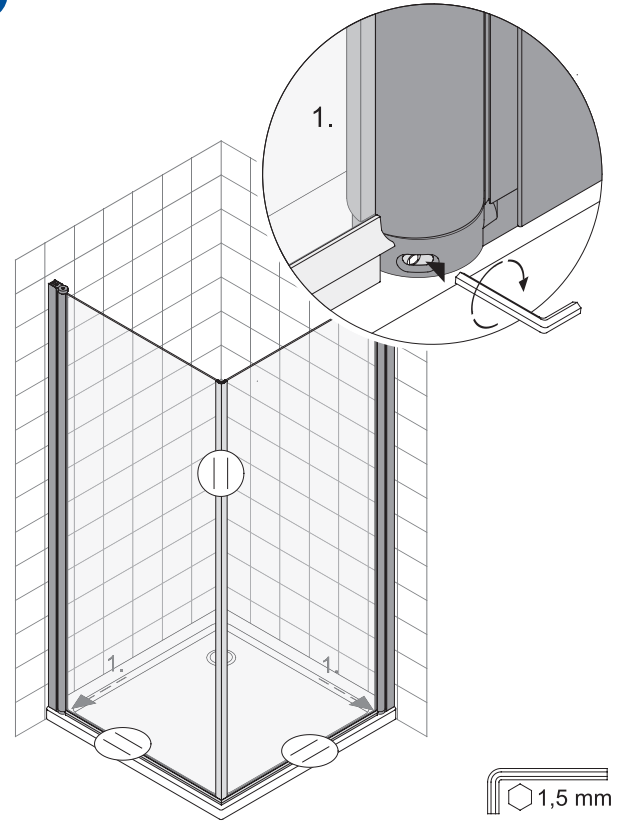

11 EFT / EPW

11

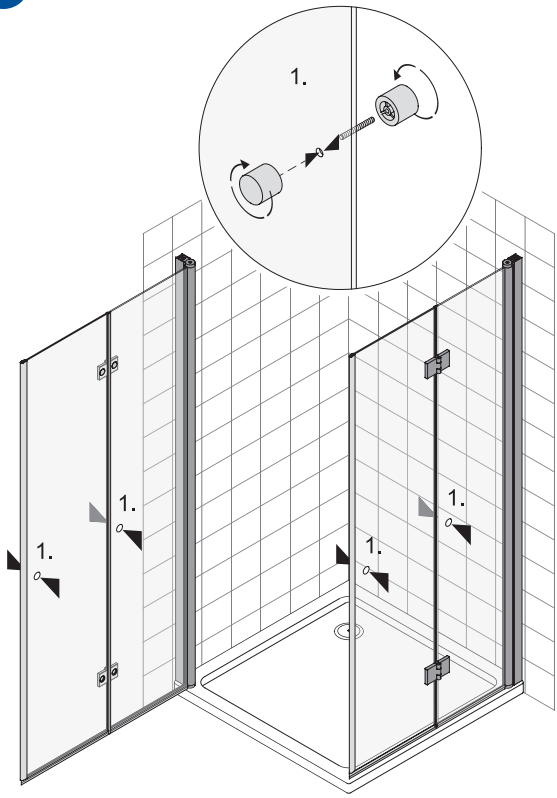

12

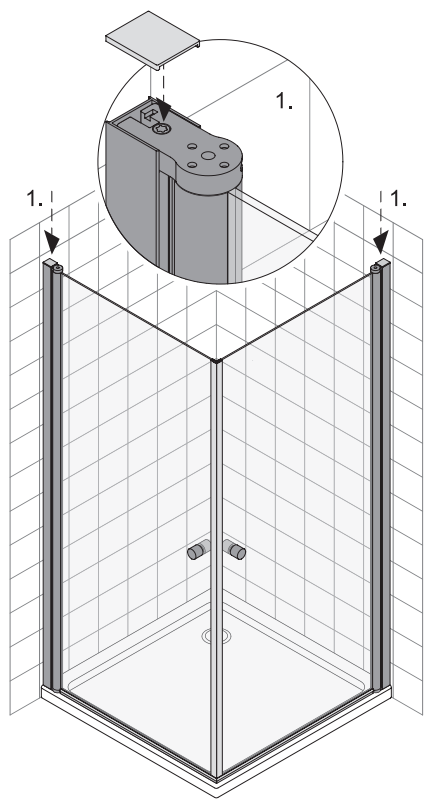

13

EPW / EFT

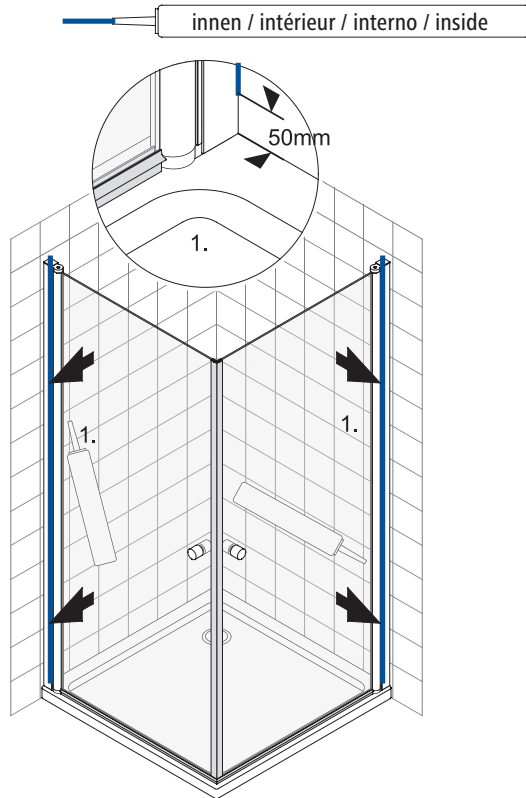

14

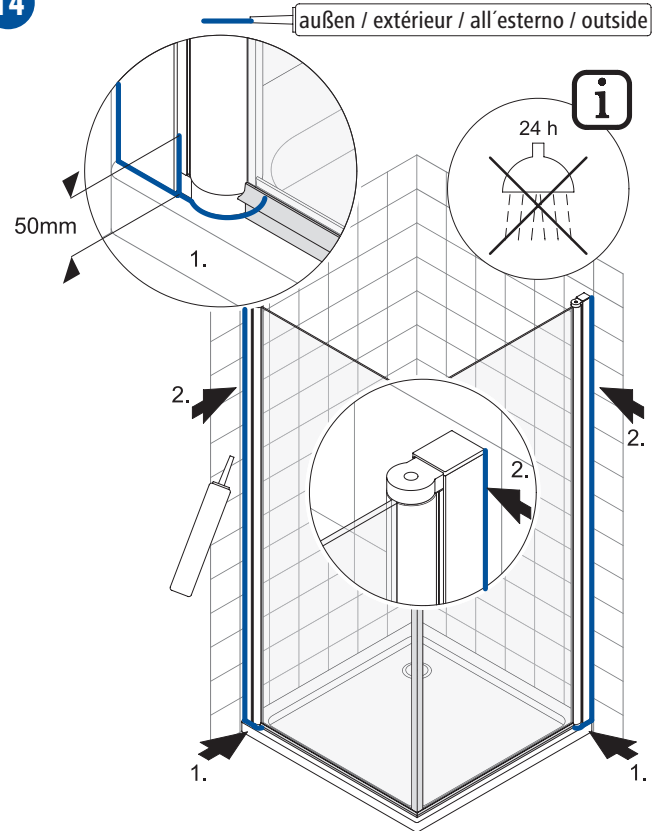

WHL Profil
supplément profil del sol
soglia a pavimento
supplement bottom profile

Die optionale Wasserhemmleiste ist dezent im Design und verbindet eine geringe Einstiegshöhe mit einem guten Schutz vor Spritzwasser. Achtung! Bei einer Installation der Duschtrennung ohne Wasserhemmleiste können Reklamationen bezüglich Wasserdichtheit nicht anerkannt werden.

Discret, le profilé d'écoulement disponible en option offre à la fois une faible hauteur d'entrée et une bonne protection contre les projections d'eau.

Attention ! En cas de pose d'une séparation de douche sans profilé d'écoulement, nous ne saurions accepter les réclamations portant sur l'étanchéité à l'eau.

La piccola soglia a pavimento è discreta nel design e combina una bassa altezza di ingresso con una buona protezione contro gli spruzzi d'acqua.

Attenzione! Quando si installa il box doccia senza soglia a pavimento, i reclami sulla resistenza all'acqua non vengono accettati.

The optional water deflector strip is discreet and combines a low threshold with excellent protection against splashes.

Attention! If the shower enclosure is installed without a water deflector strip, we shall not accept any complaints regarding water leakage.

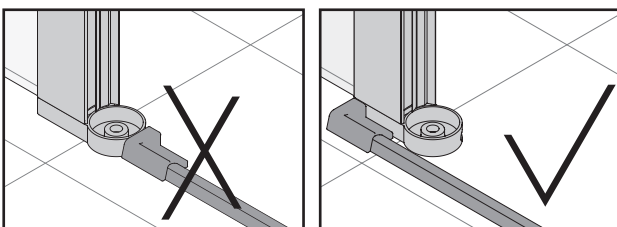

15

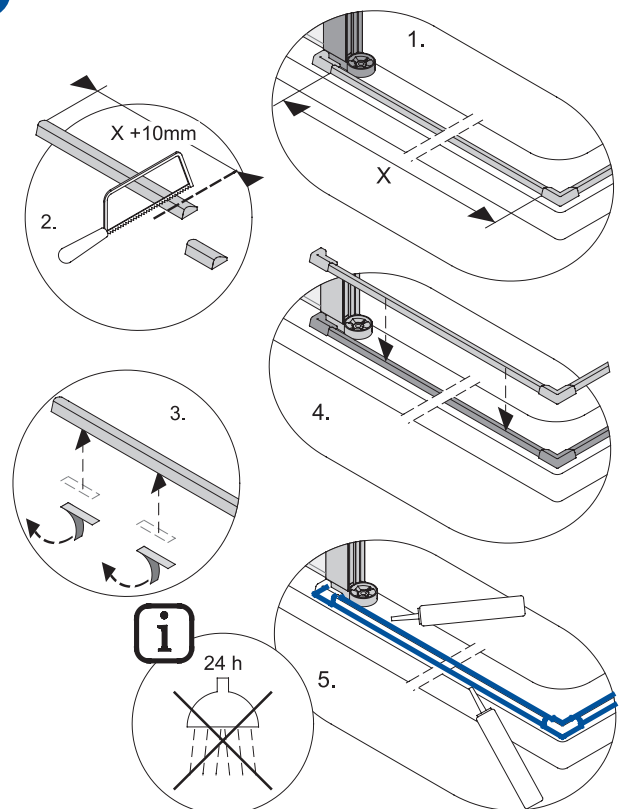

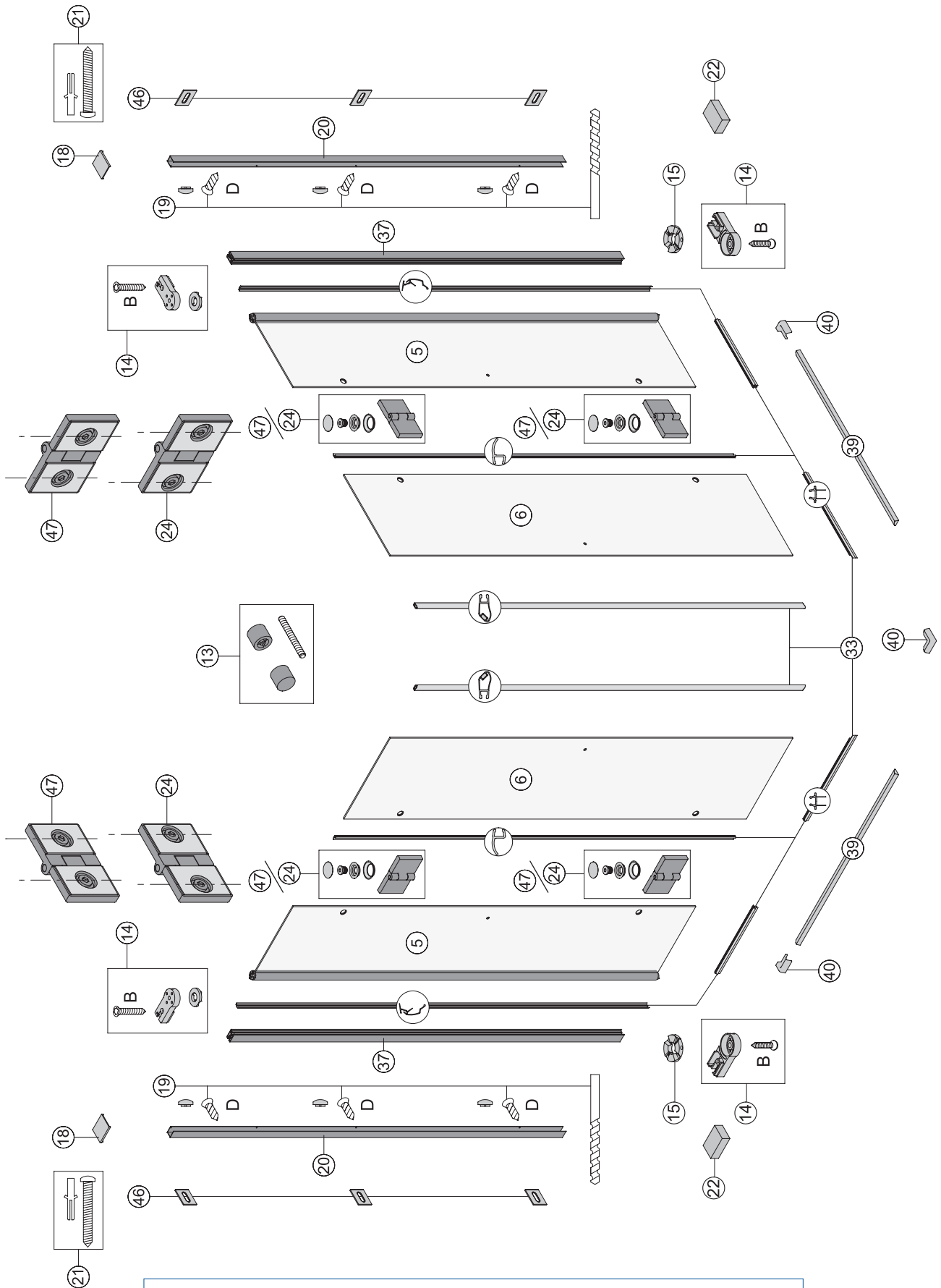

 PIN: 0000
 123456789012345678
 123456789012 → Ersatzteil / Pièce de rechange / Parte di ricambio / spare part

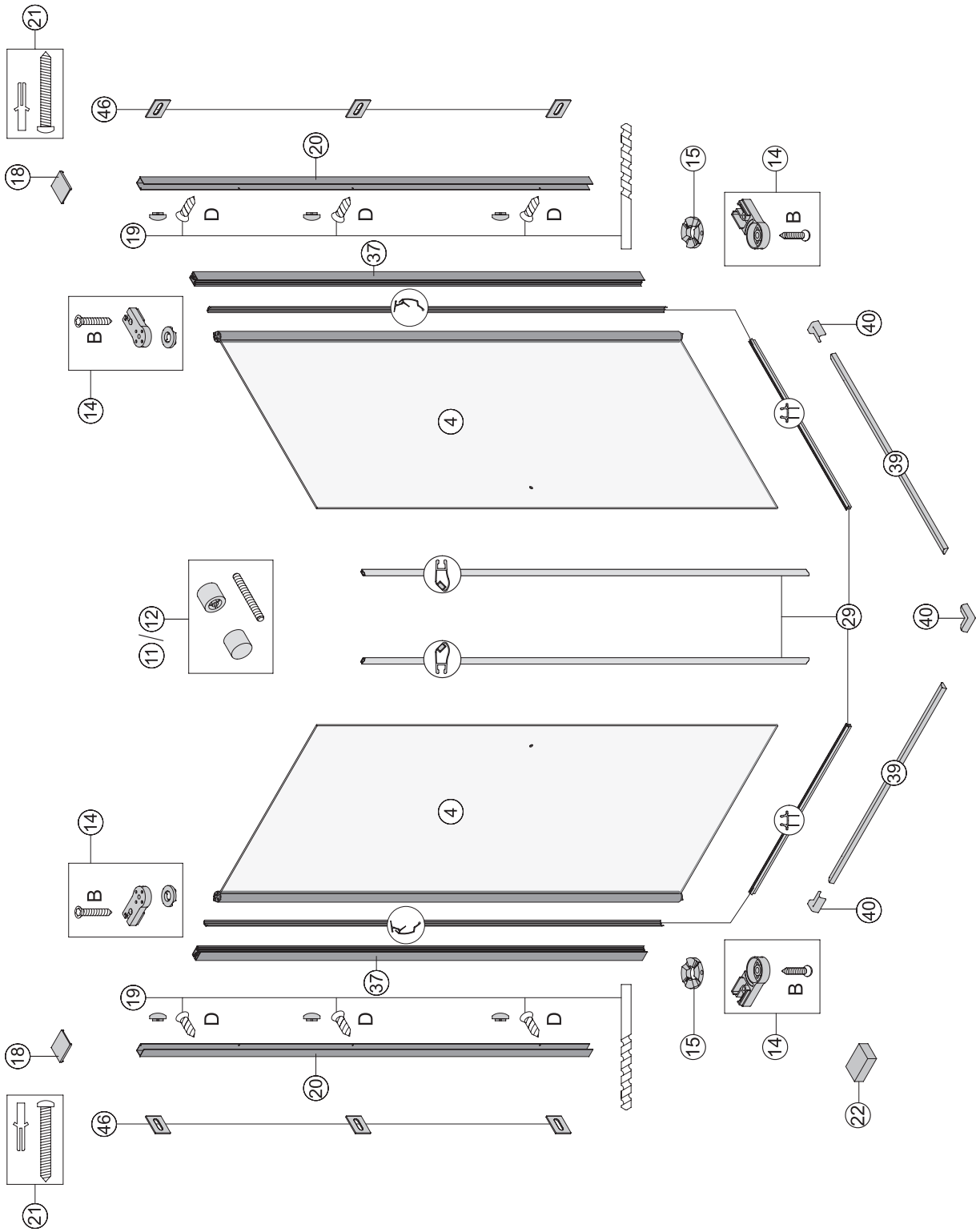

 PIN: 0000
 123456789012345678
 123456789012 → Ersatzteil / Pièce de rechange / Parte di ricambio / spare part

Technische Änderungen behalten wir uns vor.
 Für Druckfehler oder technische Verwechslungen
 übernehmen wir keine Gewähr.

Nous nous réservons le droit de procéder à des
 modifications techniques. Nous n'assurons pas
 de responsabilité pour des erreurs techniques
 ou des fautes d'impression.

Ci riserviamo il diritto di apportare modifiche tecniche
 senza obbligo di preavviso. Decliniamo ogni responsabilità
 per errori in fase di stampa riguardanti i prodotti e/o
 loro specifiche tecniche.

We reserve the right to technical amendments.
 We do not take responsibility for printing errors
 or technical confusions.